

Automatic Flatwork Separating System

PIK-QUIK™ JUMBO with CAT (Cart Auto Tram)



The Ultimate Workhorse For Untangling Your Laundry's Wet, Partially Dry Or Fully Dry Flatwork

Pik-Quik Jumbo with CAT (Cart Auto Tram)—the highest capacity sheet picking/separating system available anywhere. Complete with new, improved picking jaws and a sturdy extra large cart for greater output—its loading capacity is now up to 350 lbs. per load, so it can handle up to 3-110 lbs., 2-150 lbs. or 1-250 lbs. cakes from a tunnel washer. The pounds per minute pick ratio produces as much as 30% more linen per hour than the original Pik-Quik. When used with Chicago's King Edge or Edge Maxx spreader feeder, it will reliably process over 1,000 sheets per hour making it perfect for users with larger tunnels and batch sizes. Laundry operators who are looking for ways to redeploy valuable FTE's, improve ergonomics for their employees and reduce their cost per pound to produce finished linen should see that the Pik-Quik Jumbo with CAT makes great "hard dollar" ROI sense to add to one or more ironing lines. Pik-Quik Jumbo is the biggest advance in linen separation since the original was introduced and became the leading linen separating system in the world.

Pik-Quik JUMBO

Dimensions and Utilities

| CONNECTION(S) | DIA. | HEIGHT |
|-------------------------|------|-------------|
| A Air Connection | 1/2" | 114" [2896] |
| B Compressed Air Drain | -- | 64" [1626] |
| E Electrical Connection | -- | 109" [2769] |

| SHIPPING WEIGHT | |
|--------------------|-------------|
| Domestic, lb. [kg] | 3858 [1750] |

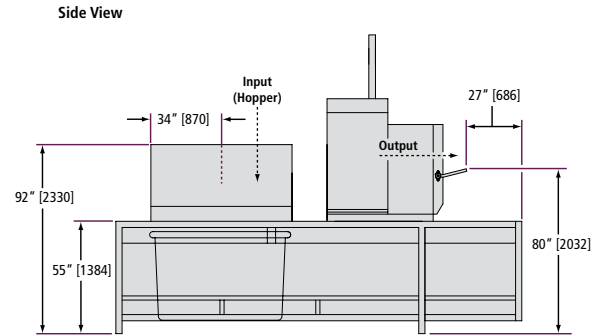
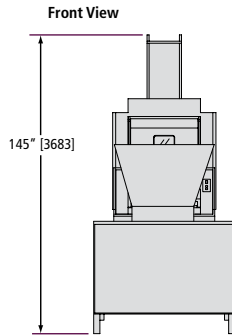
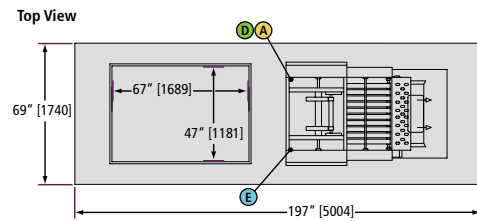

NOTE:

1. Specifications subject to change without notice. Consult factory for certified construction floor plan.
2. Metric dimensions are in [].
3. All dimensions are $\pm 1/2$ ".
4. Utility connections are located as shown.

Why You Need Pik-Quik Jumbo

Like the original Pik-Quik system, Pik-Quik Jumbo ends the time consuming and physically stressful process of unloading wet, tangled, heavy linen from cart systems by hand. The addition of this piece of equipment dramatically reduces the bending, twisting and lifting required of laundry employees who have to prepare the wet, heavy linen for feeding through flatwork ironers or

folders. By improving the ergonomic efficiency of the process and eliminating the job's physically demanding stresses, Chicago has managed to unjam this costly and time-consuming bottleneck to help your laundry facility handle a far greater output than ever, while streamlining linen flow and improving working conditions.

CAT Automated Loading System

CAT (Cart Auto Tram) System receives tangled linen directly from an overhead sling or conveyor drop into a specially designed integral separating cart. The loaded cart then automatically moves across a built-in track system into position under Pik-Quik's picking head for linen separation. Upon completion, the substantially

emptied cart automatically returns to loading position to receive the next batch of incoming linen. Working in conjunction with Pik-Quik Jumbo, the larger, updated CAT system allows heavier linen volume to be processed, and can be configured to receive linen from the front, left or right side.

A Complete Range of Separating, Feeding, Ironing, Folding and Sorting Options

Because Chicago specializes only in flatwork finishing equipment, it can offer the world's widest range of high production separating, feeding, ironing, folding and sorting equipment. Complete flatwork finishing systems range from automated multi-roll systems producing over 2000 pounds per hour, to compact ironers for small on-premise laundries.

Chicago's performance record is unmatched in thousands of installations in commercial, hospitality, health care, textile rental, institutional and on-premise laundries all over the world. An experienced Chicago professional will be pleased to make an objective

equipment recommendation based on your production, space, utility and budget requirements. Contact your local Chicago distributor or the factory sales assistance office for a no-obligation analysis of your needs.

Chicago's Customer Service department offers full technical and service support by telephone and on our website. We also offer overnight service for quick parts availability. Visit our website, www.chidry.com, to learn more about our complete line of flatwork finishing systems, including video of Chicago® equipment in action.



CHICAGO DRYER COMPANY
2200 North Pulaski Road
Chicago, Illinois 60639-3737 USA

Phone • 773.235.4430
Fax • 773.235.4439
Web • www.chidry.com
Email • chicago@chidry.com